

ZUNDA GASGRILL MGG-341



Art. Nr.: 30100129



ZUNDA
GASGRILL

- DE** GASGRILL Montageanleitung
- EN** GAS GRILL Assembly Instructions
- FR** BARBECUE À GAZ Guide de montage
- ESP** BARBACOA DE GAS Instrucciones de Montaje
- IT** BARBECUE A GAS Istruzioni di Montaggio



GASGRILL • GAS GRILL • BARBECUE À GAZ
BARBACOA DE GAS • BARBECUE A GAS

DE

Bitte vor dem ersten Gebrauch beachten!

Die Edelstahloberflächen Ihres Grills sind ab Werk mit einem Öl behandelt, das die Oberflächen vor Verschmutzungen schützen soll. Dieses Öl ist gesundheitlich unbedenklich, verursacht jedoch Verfärbungen durch die Hitzeeinwirkung während des Gebrauchs. Reinigen Sie die Oberflächen des Grills deshalb vor dem ersten Gebrauch gründlich mit einem weichen Lappen und einem milden, fettlösenden Mittel (Spülmittellösung, Spiritus, Reinigungsalkohol).

Hinweis:

Edelstähle verfärben sich durch Hitzeeinwirkung (meist bläulich und/oder gelblich-braun). Dies ist materialbedingt und kein Defekt und damit kein Reklamationsgrund.

EN

Please read before the first use!

The stainless steel surfaces of your grill are treated from factory with an oil, which should protect them from the dirty. This oil is harmless, but it causes discolorations through the effects of the heat during use. Clean the surfaces with a soft cloth and with a delicate, degreasing agent (dishwashing detergent solution, spirit, rubbing alcohol).

Note:

Stainless steels become discoloured because of the effects of the heat (mostly bluish or yellowish-brown). This is determined by the material and it is no defect, therefore it constitutes no reason for complain.

FR

S'il vous plaît vérifier avant la première utilisation!

Les surfaces en acier inoxydable de votre grill sont traitées à l'usine avec une huile pour protéger la pollution de surface. Cette huile n'est pas nocive pour la santé, mais provoque la décoloration sous l'influence de chaleur pendant l'usage. Nettoyer donc complètement les surfaces du grill, avant la première utilisation avec un chiffon mou et des produits de dégraissages doux (Liquide vaisselle, l'alcool, alcool de nettoyage).

Remarque:

Les aciers inoxydables changent de couleur sous l'influence de chaleur (le plus souvent bleuâtre et/ou jaunâtre brun). Cela tient du matériau et n'est donc pas un défaut et de cela ne peut résulter aucune réclamation.

ES

¡Por favor tome en cuenta antes del primer uso!

Las superficies de acero inoxidable de la barbacoa son tratadas de fábrica con un aceite con la finalidad de protegerlas de la suciedad. Este aceite no es perjudicial para la salud, sin embargo causa la decoloración por la acción del calor durante el uso. Por lo tanto, antes de la primera utilización, limpie las superficies de la barbacoa a fondo con un paño y un producto desengrasante suaves (solución detergente para lavavajillas, alcohol, alcohol para limpieza).

Nota:

Los aceros inoxidables se decoloran por la influencia del calor (por lo general azulado y/o marrón amarillento). Esto es causado por el material y no se trata de un defecto, por lo tanto no constituye motivo de reclamación.

IT











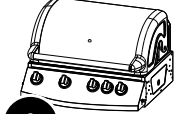
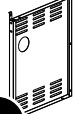
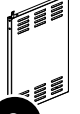
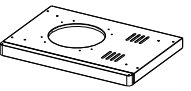

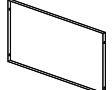
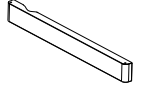
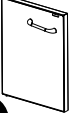
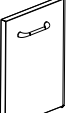
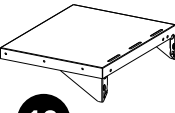
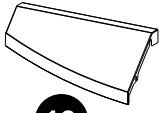
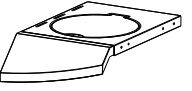
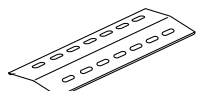
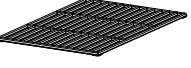

Si prega di leggere prima del primo utilizzo!

Le superfici in acciaio inox del barbecue sono trattate di fabbrica con un olio, che deve proteggerle dalle impurità. Questo olio non comporta rischi per la salute, ma può causare scolorimenti a causa dell'effetto del calore durante l'utilizzo. Pulire accuratamente le superfici del barbecue prima del primo utilizzo con un panno morbido e con un mezzo delicato e sgrassante (soluzione di detersivo per piatti, spirito, alcool per pulizia).

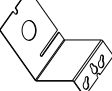
Avvertenza:

Gli acciai scoloriscono a causa dell'effetto del calore (perlopiù diventano bluastri e/o marrone giallastri). Ciò è determinato dal materiale e non è un difetto, per questo non costituisce motivo di reclamo.

GELIEFERTE EINZELTEILE • DELIVERED ITEMS • PIÈCES LIVRÉES • ARTÍCULOS SUMINISTRADOS • COMPONENTI FORNITI

 1 1 pcs	 2 1 pcs	 3 1 pcs	 4 1 pcs
 5 1 pcs	 6 2 pcs	 7 2 pcs	 8 1 pcs
 9 1 pcs	 10 1 pcs	 11 1 pcs	 12 1 pcs
 13 1 pcs	 14 1 pcs	 15 4 pcs	 16 2 pcs
 17 1 pcs	 18 1 pcs	 19 1 pcs	 20 1 pcs
 21 1 pcs	 22 4 pcs	 A M4-6 2 pcs	 B M6-10 34 pcs
 C M5-10 4 pcs	 D M5 2 pcs		

MONTAGEANLEITUNG • ASSEMBLY INSTRUCTIONS • GUIDE DE MONTAGE • INSTRUCCIONES DE MONTAJE • ISTRUZIONI DI MONTAGGIO

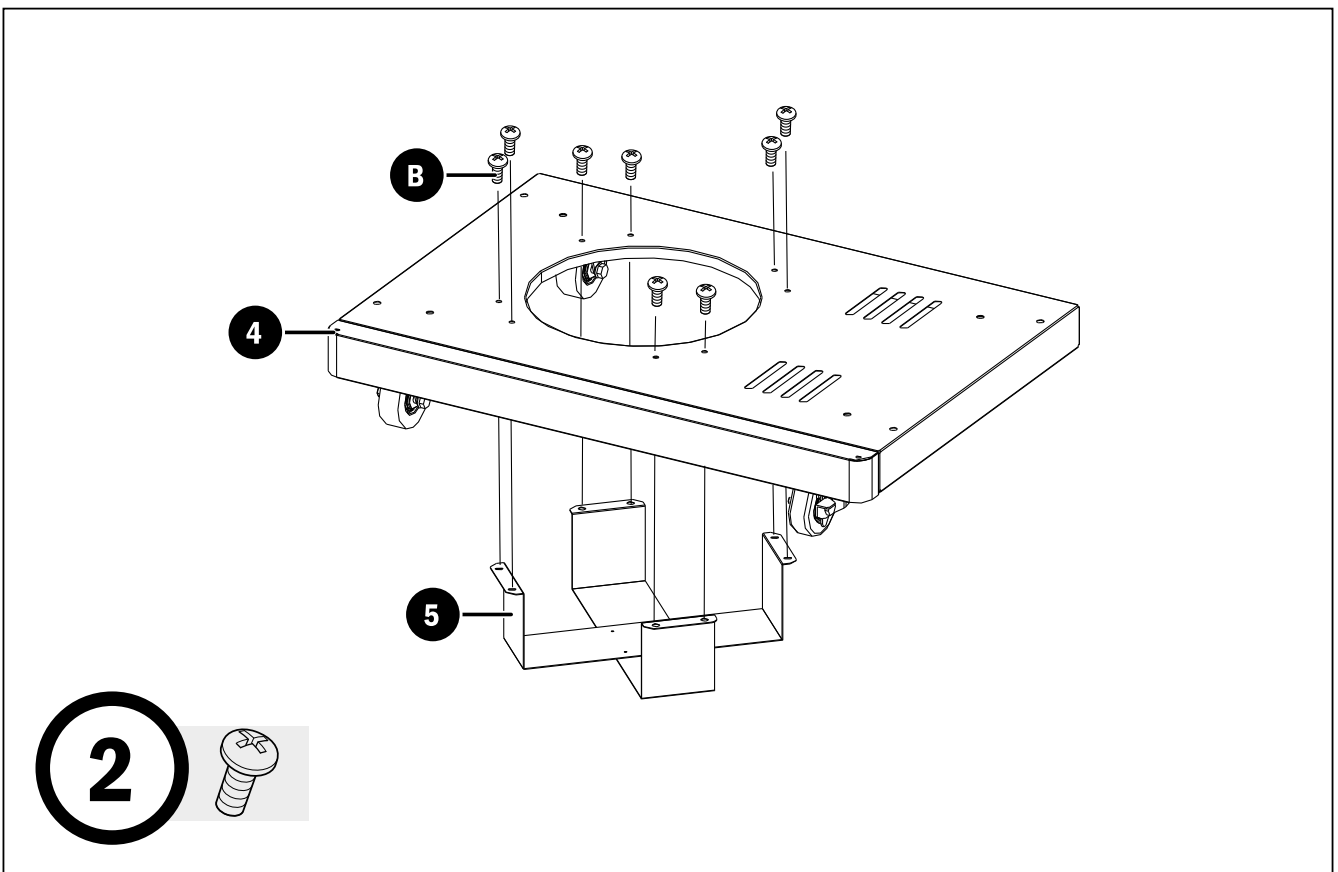
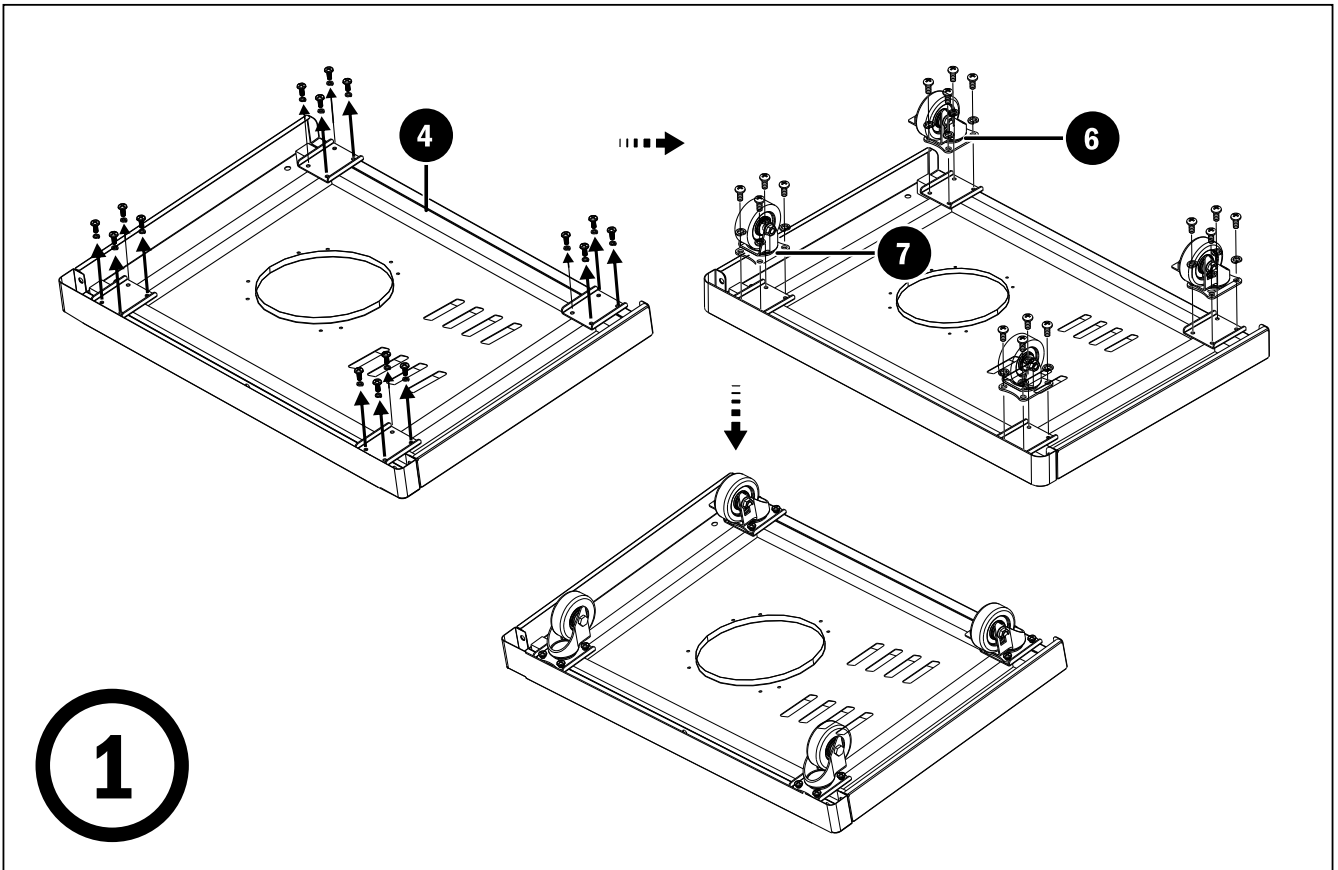

MONTAGEANLEITUNG • ASSEMBLY INSTRUCTIONS • GUIDE DE MONTAGE • INSTRUCCIONES DE MONTAJE • ISTRUZIONI DI MONTAGGIO

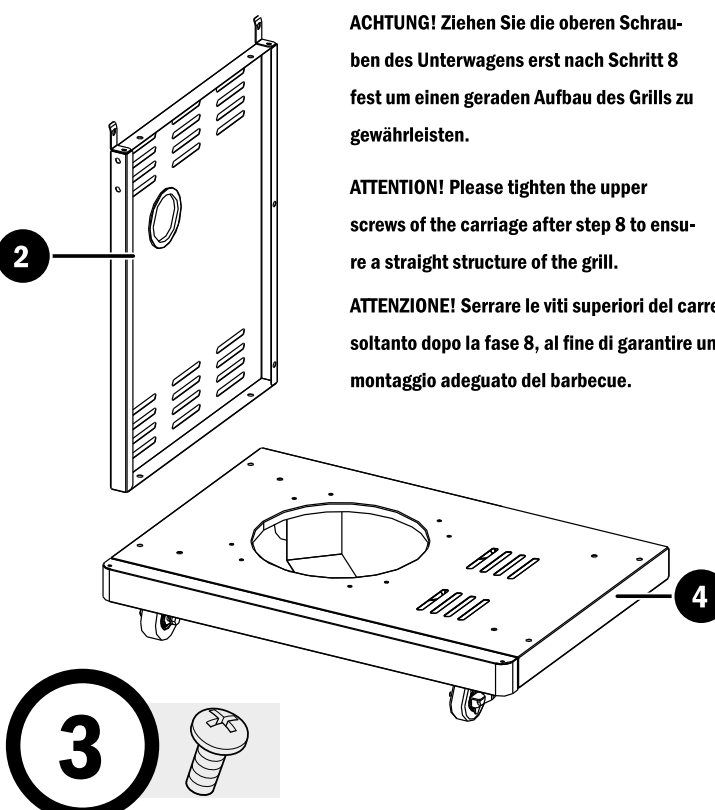

2

3

4

ACHTUNG! Ziehen Sie die oberen Schrauben des Unterwagens erst nach Schritt 8 fest um einen geraden Aufbau des Grills zu gewährleisten.

ATTENTION! Please tighten the upper screws of the carriage after step 8 to ensure a straight structure of the grill.

ATTENZIONE! Serrare le viti superiori del carrello soltanto dopo la fase 8, al fine di garantire un montaggio adeguato del barbecue.

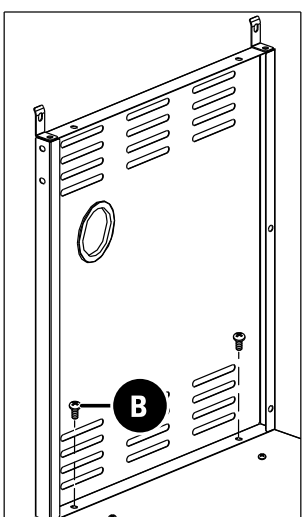

B

ATTENTION ! Ne serrez les vis supérieures du chariot inférieur qu'après l'étape 8 pour assurer la stabilité du barbecue.

¡ATENCIÓN! Con el fin de garantizar el montaje adecuado de la barbacoa, apriete firmemente el tornillo superior del carro después del paso 8.

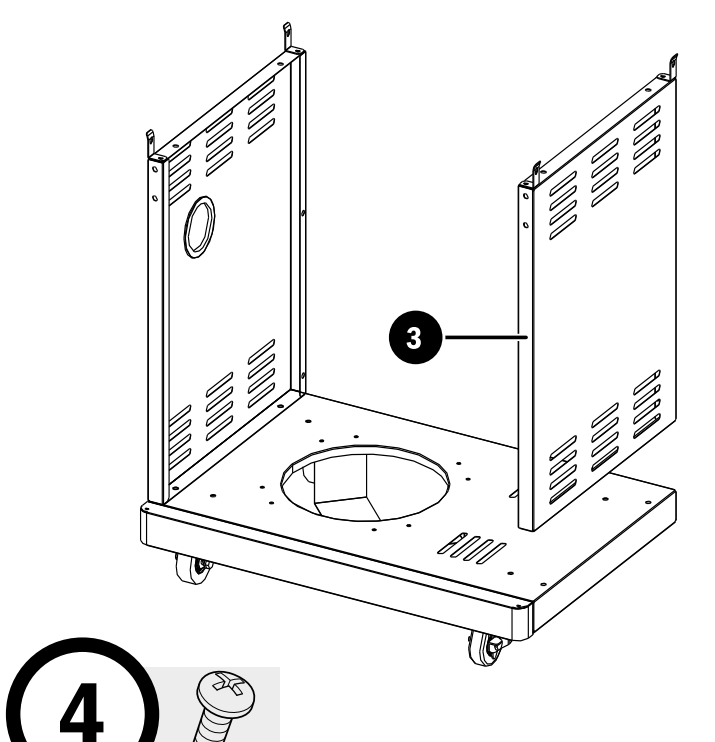

3

4

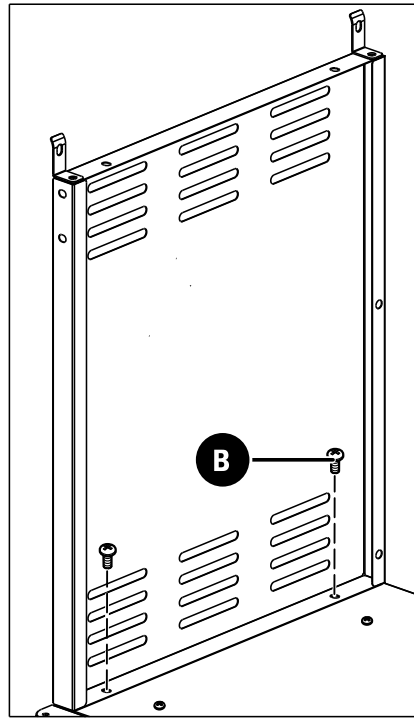

B

MONTAGEANLEITUNG • ASSEMBLY INSTRUCTIONS • GUIDE DE MONTAGE • INSTRUCCIONES DE MONTAJE • ISTRUZIONI DI MONTAGGIO

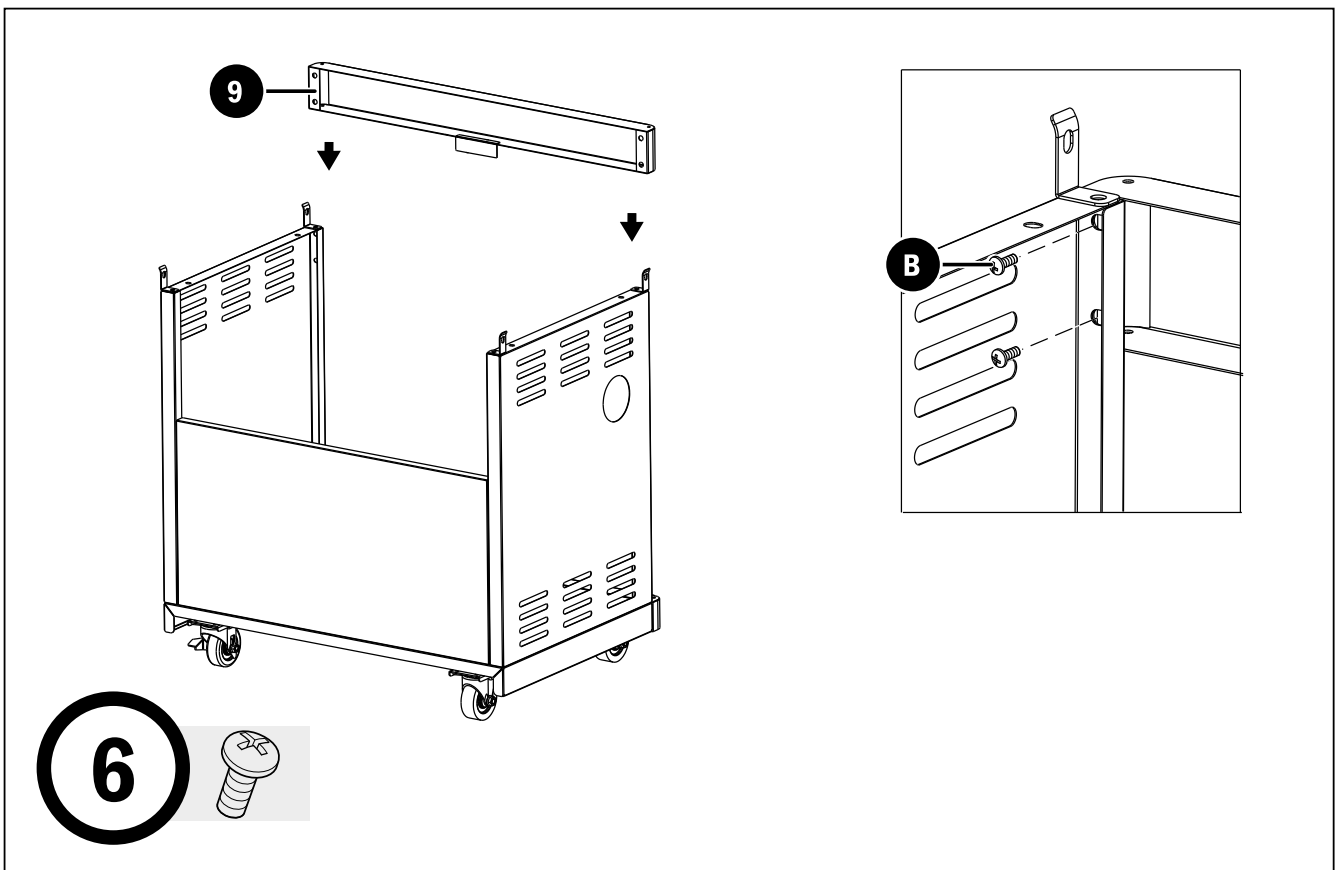
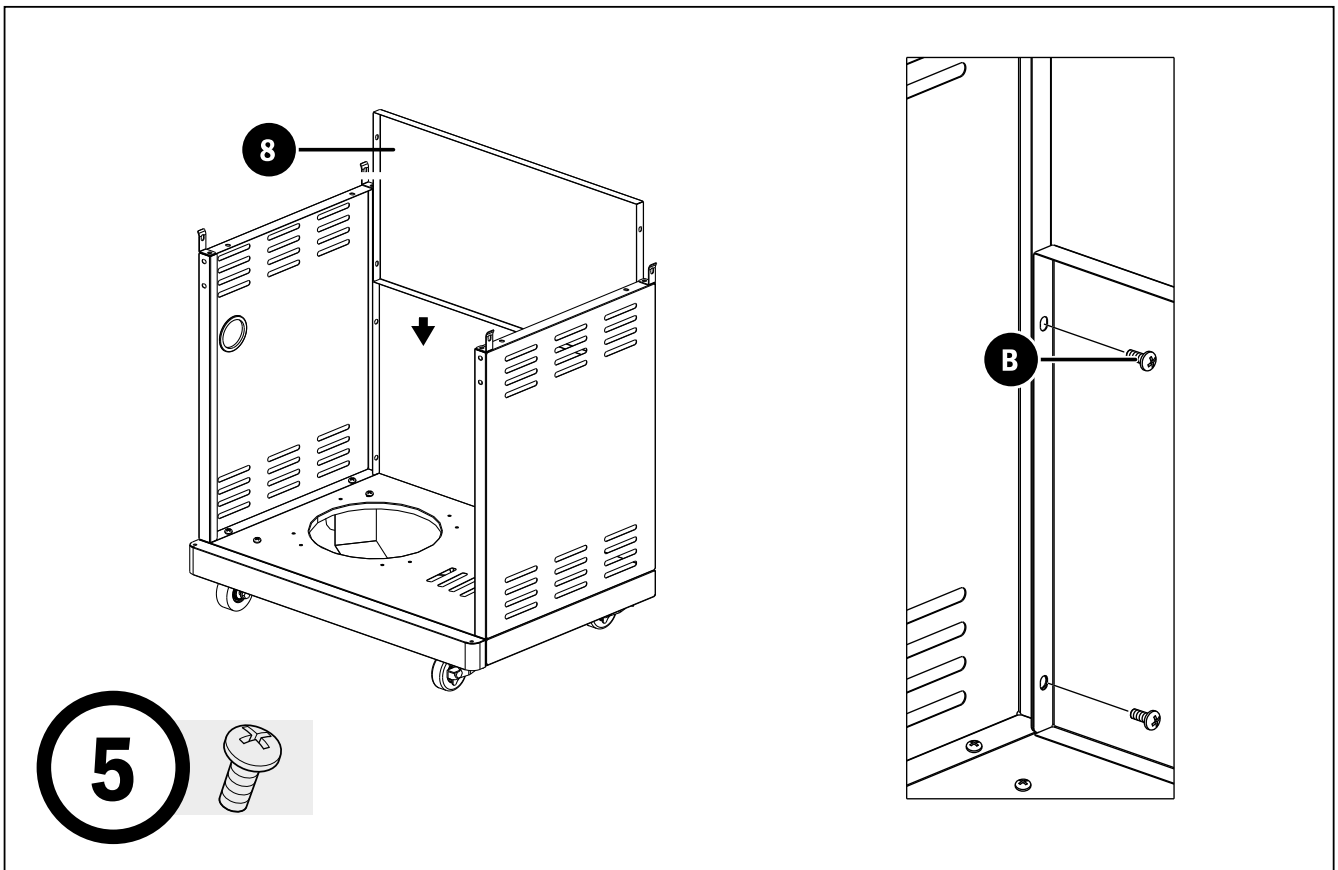

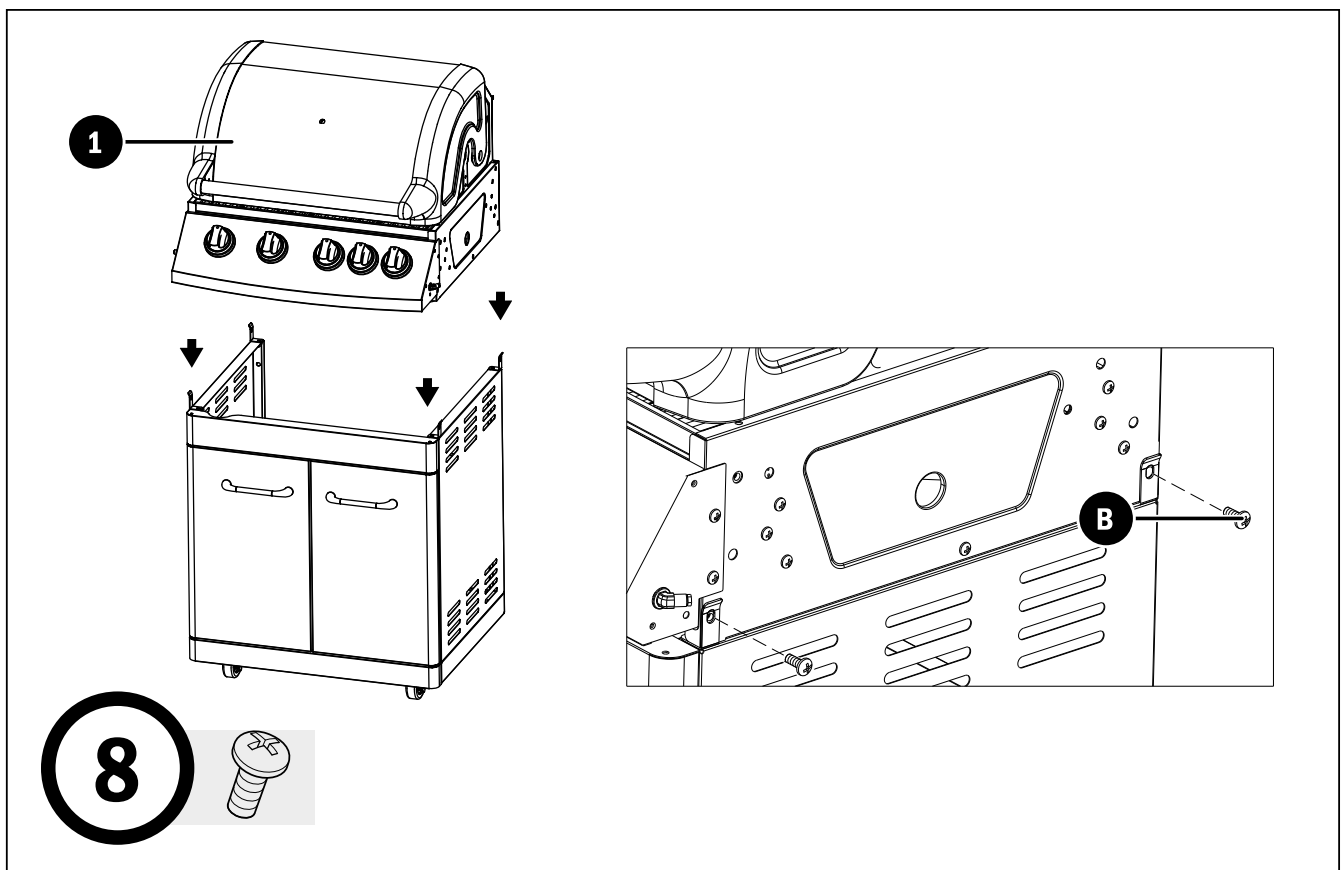
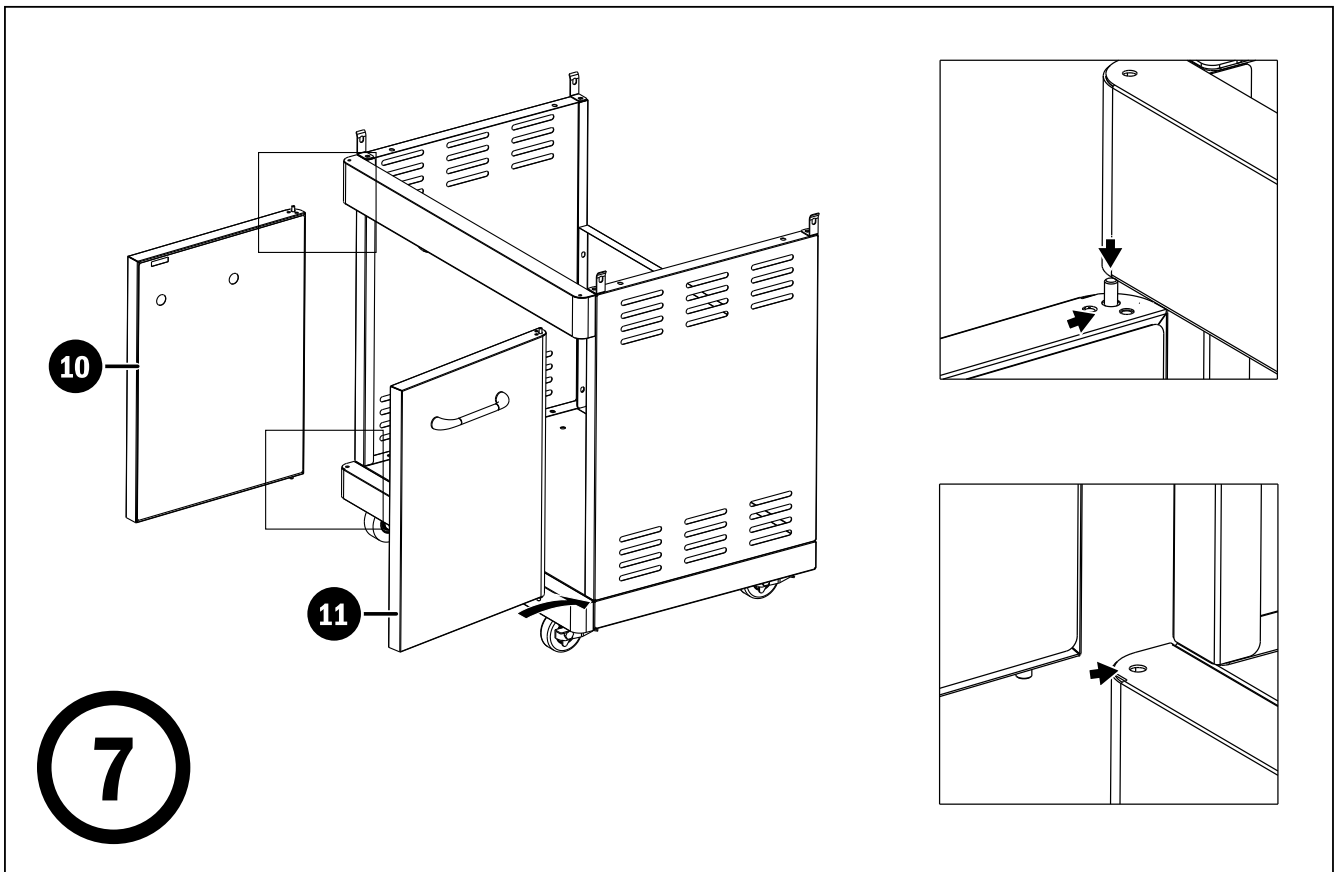

MONTAGEANLEITUNG • ASSEMBLY INSTRUCTIONS • GUIDE DE MONTAGE • INSTRUCCIONES DE MONTAJE • ISTRUZIONI DI MONTAGGIO

Ziehen Sie nun die oberen Schrauben des Unterwagens fest.

Tighten the upper screws of the carriage.

Maintenant, serrez les vis supérieures du chariot inférieur.

Ahora apriete los tornillos de la parte superior del carro.

Serrare adesso le viti superiori del carrello.

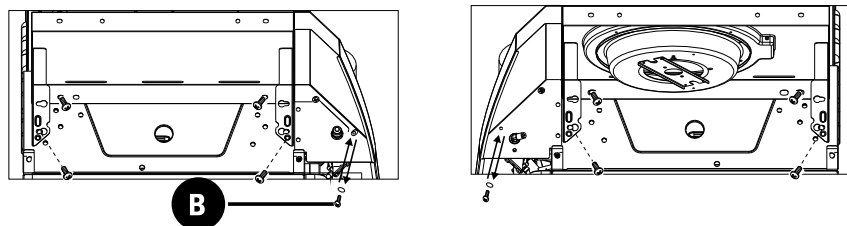
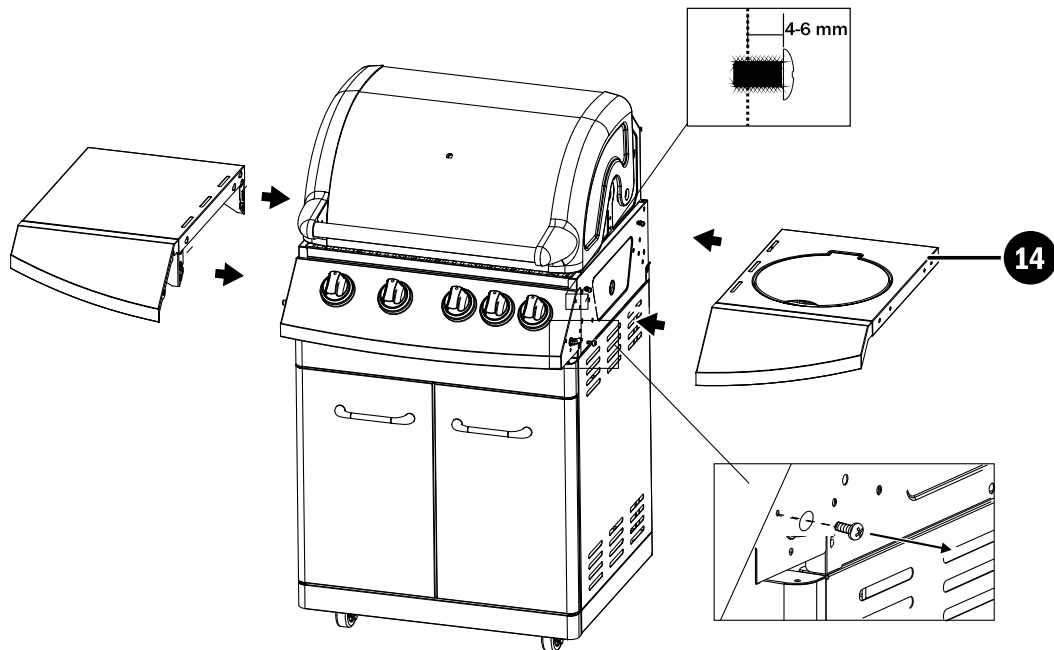
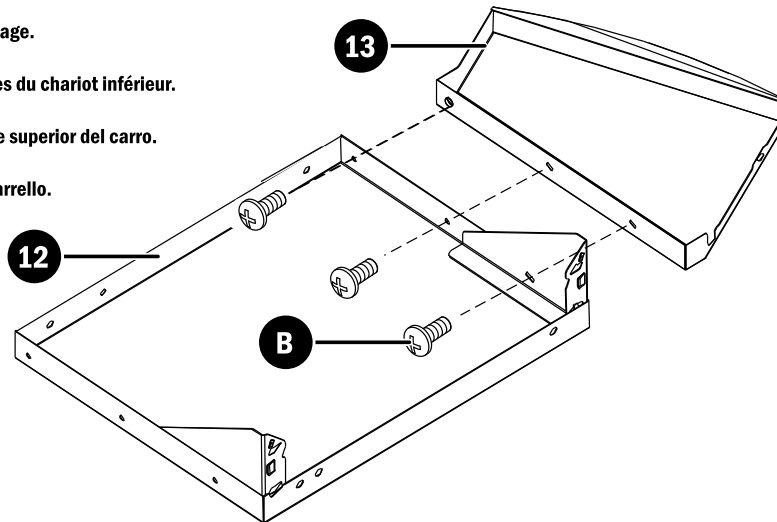

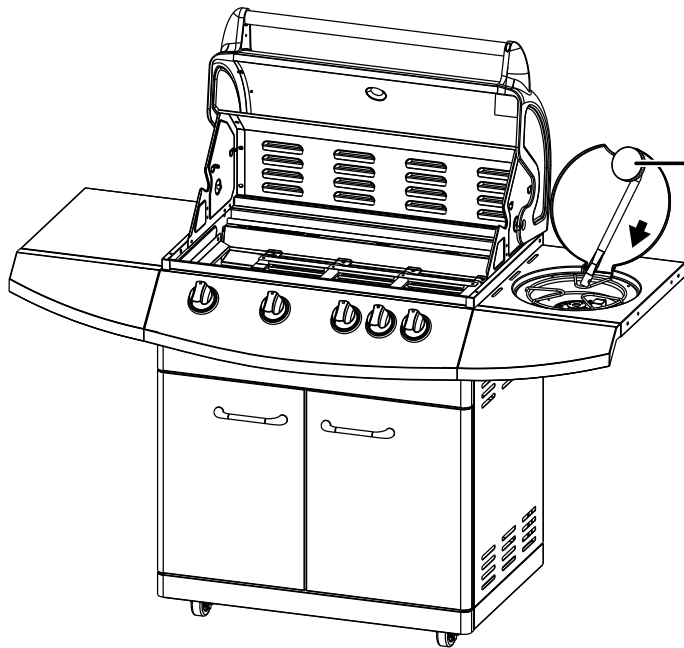

18

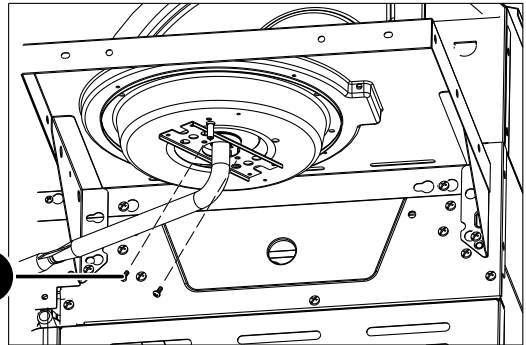
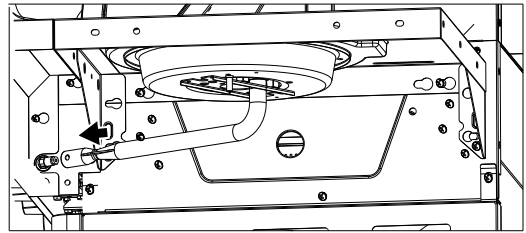

11

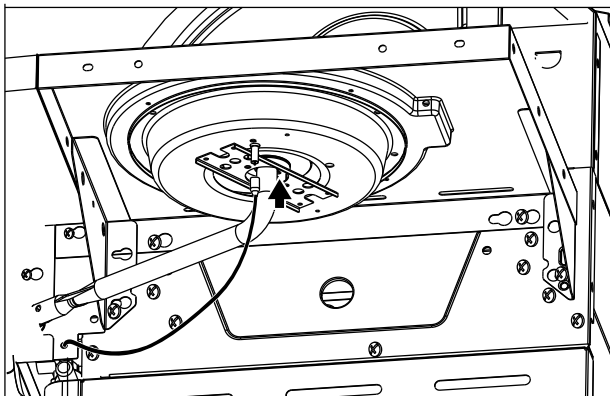

12

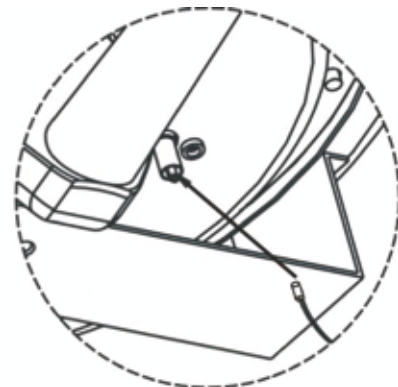

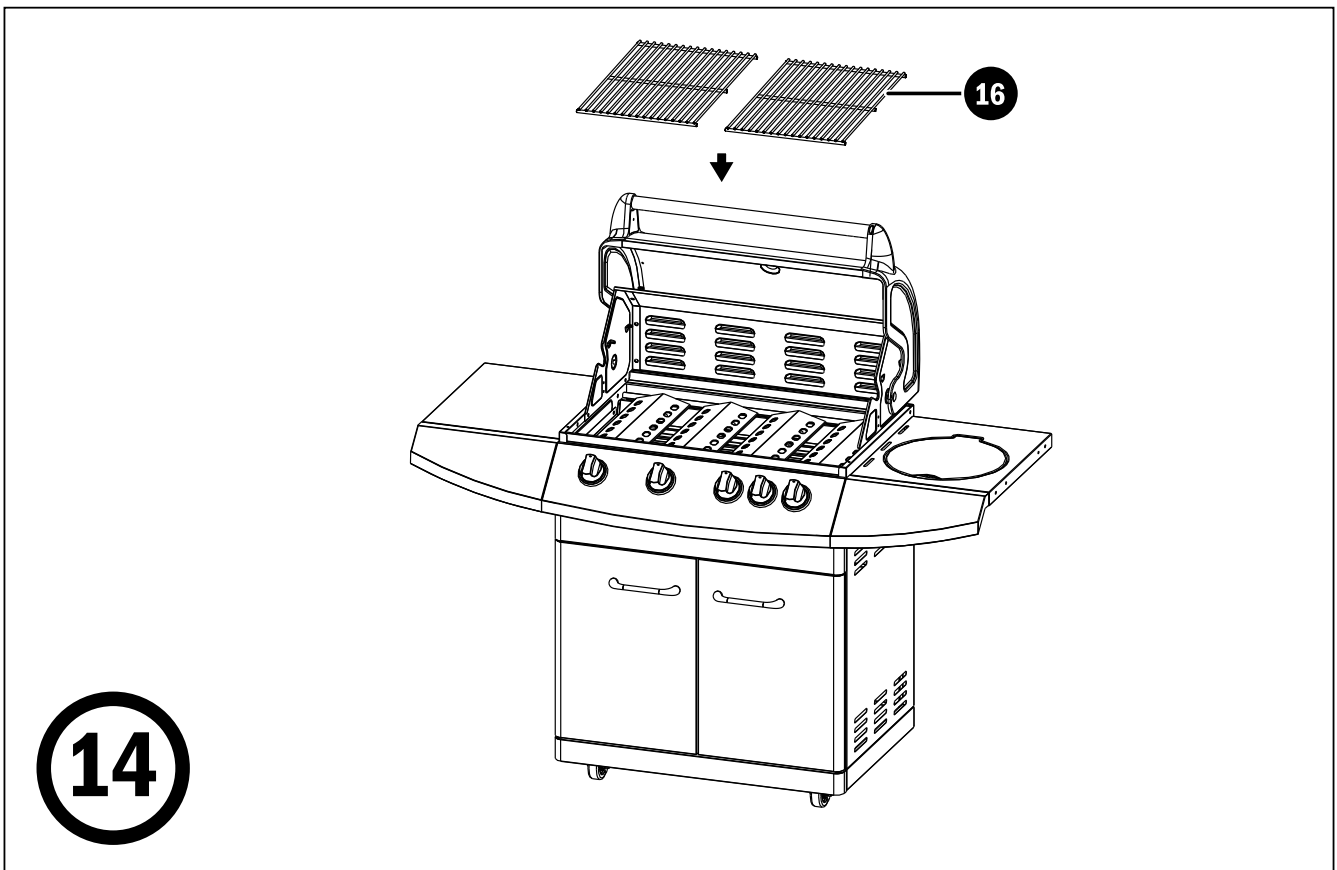
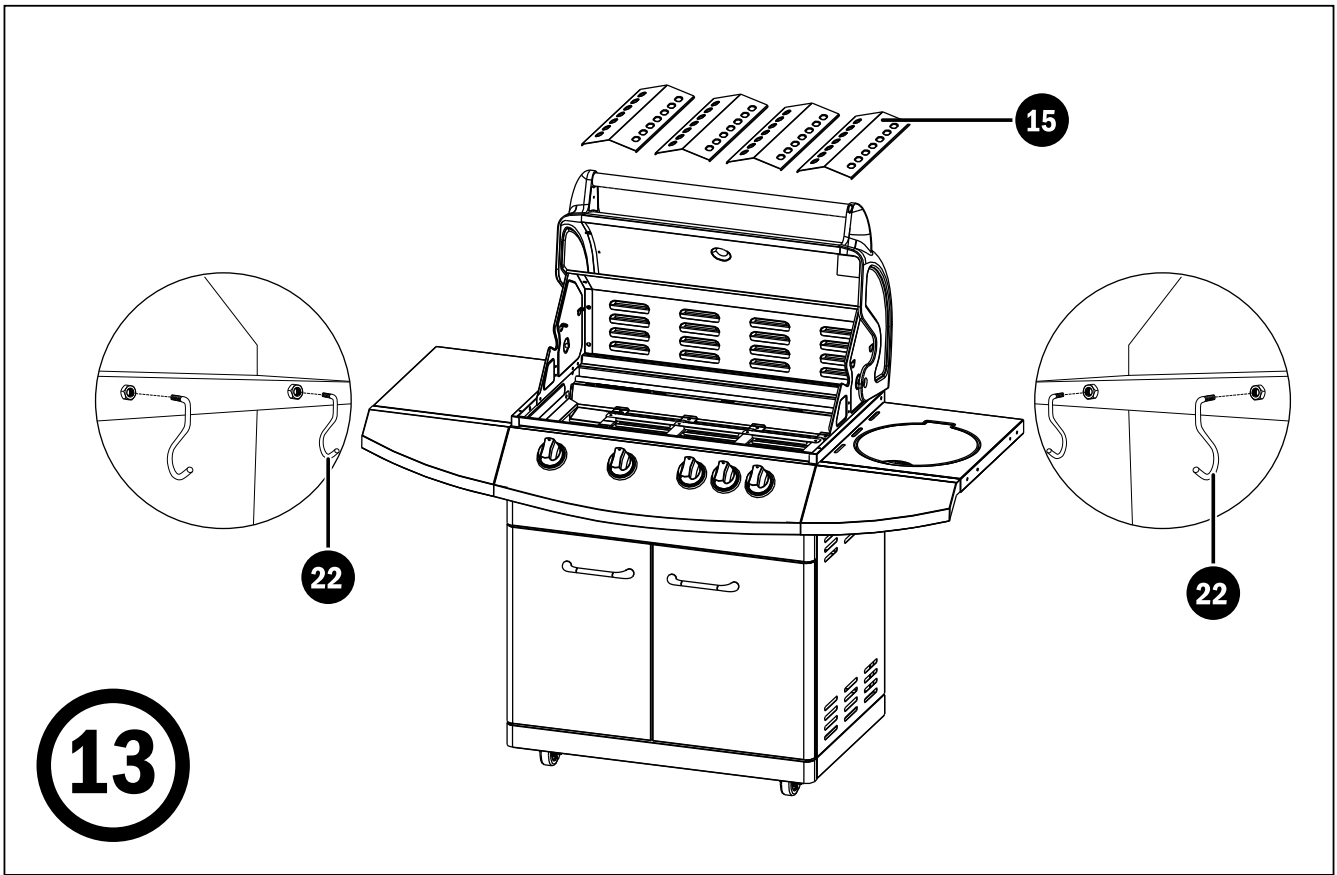

15

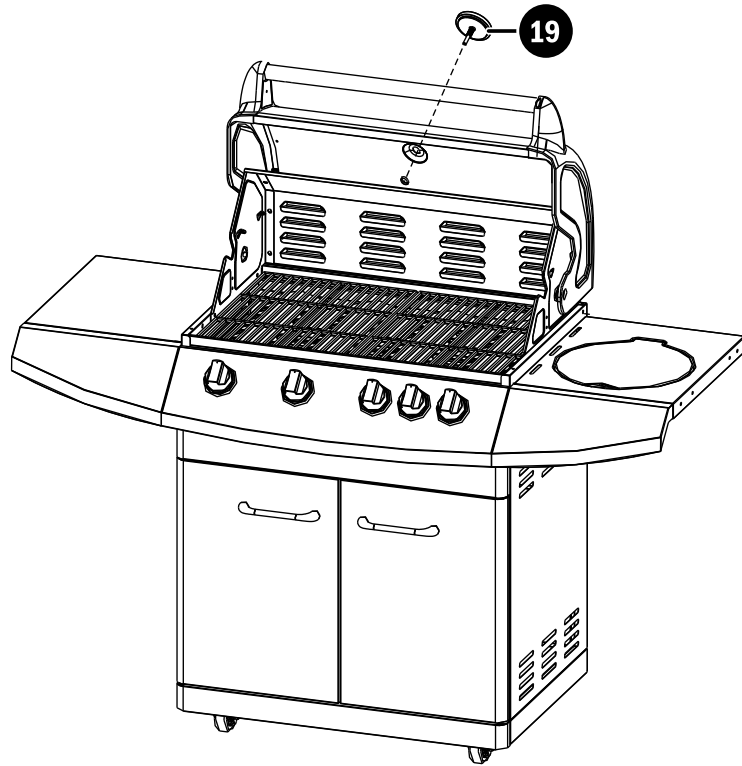

16

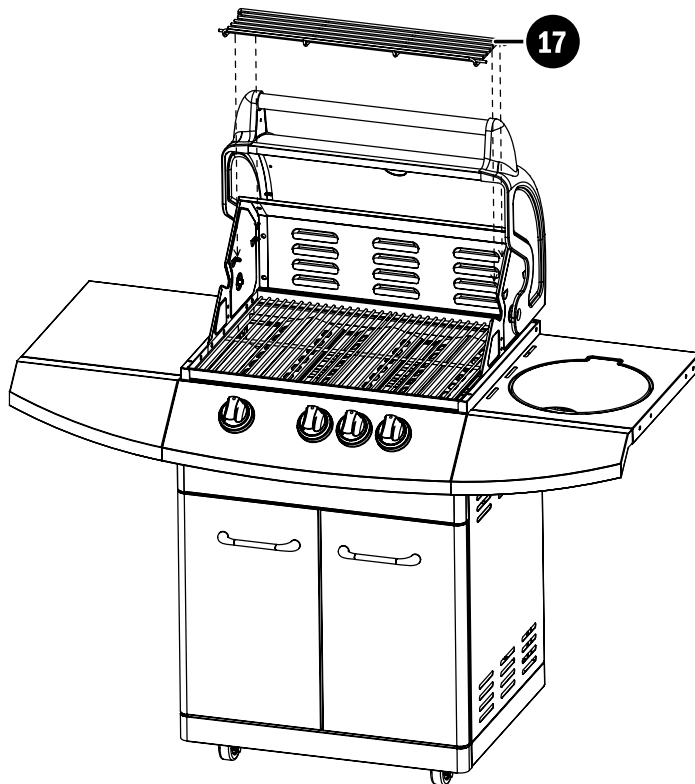

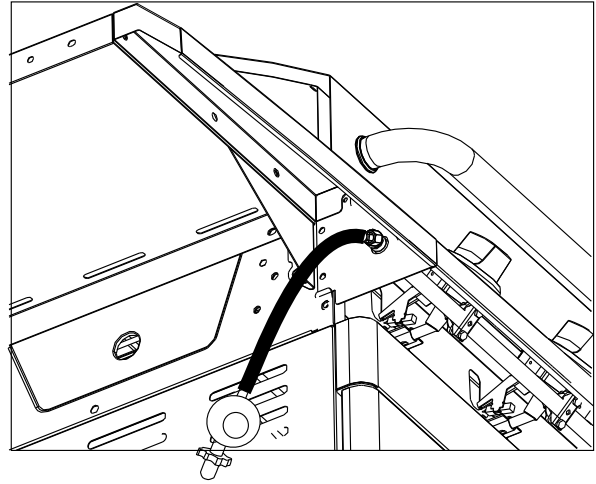
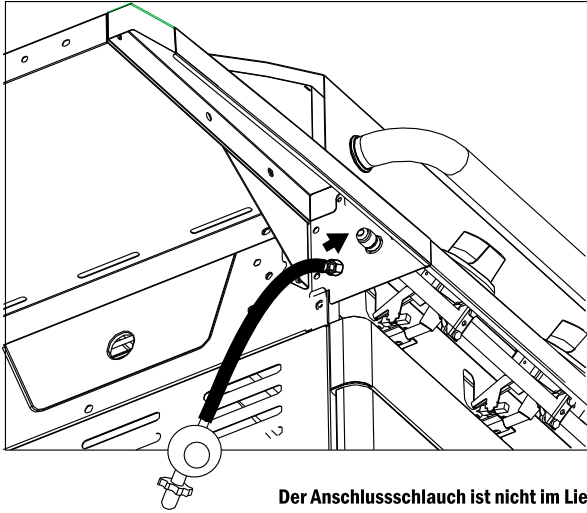

Der Anschluss Schlauch ist nicht im Lieferumfang enthalten!

The connection hose is not included in the scope of the delivery!

Le tuyau de raccordement n'est pas inclus!

La manguera de conexión no está incluida en el envío!

Il tubo di collegamento non è incluso nella spedizione!

17

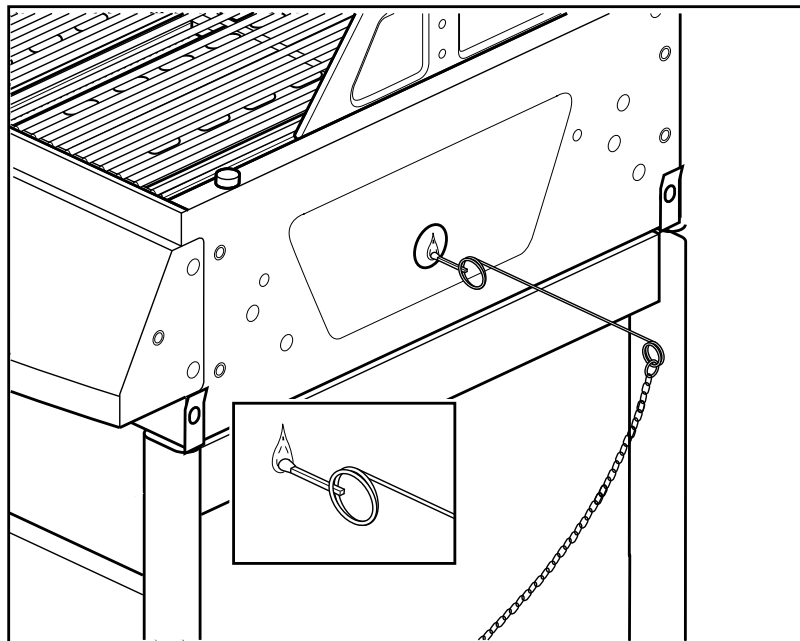

18

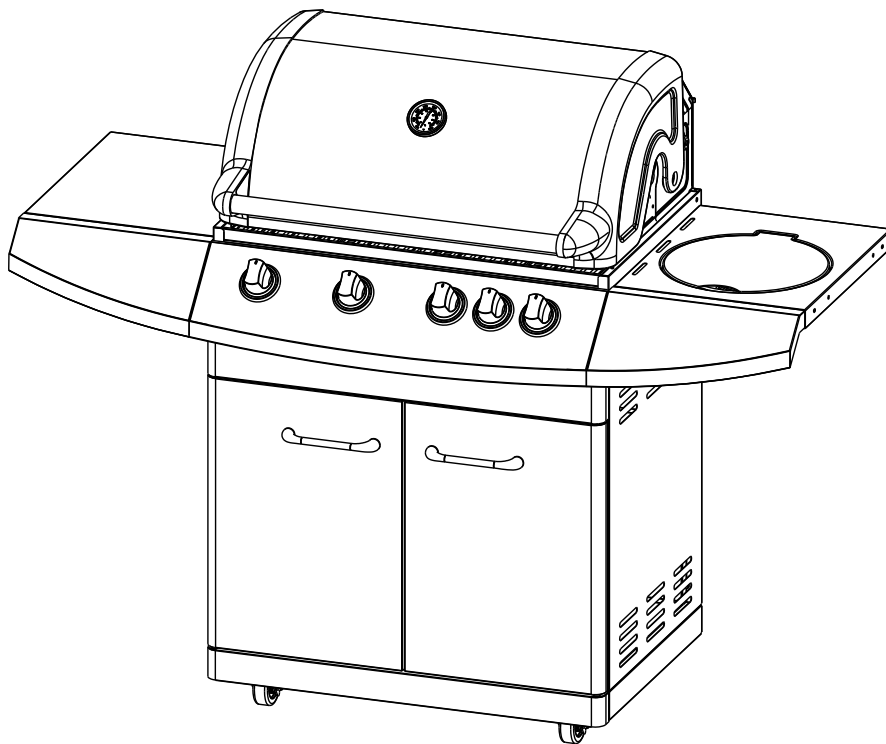
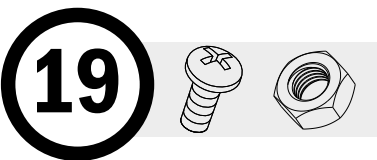
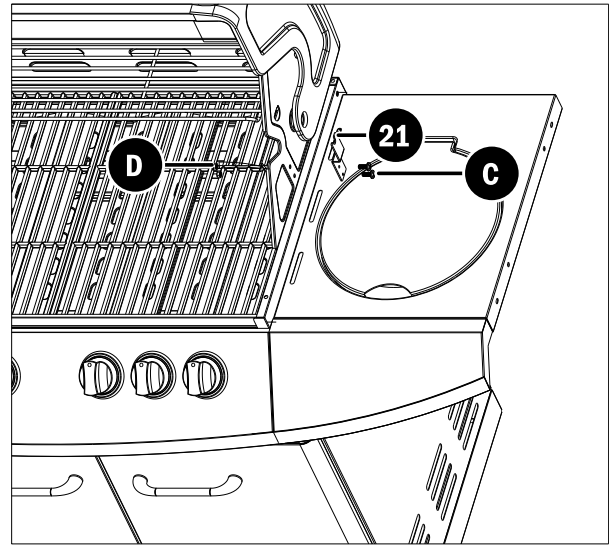
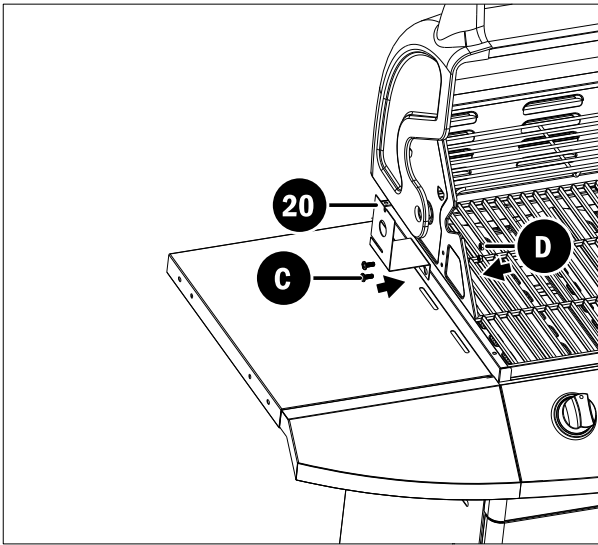

NUTZUNGSBESTIMMUNGEN • CONDITIONS OF USE • CONDITIONS D'UTILISATION • CONDICIONES DE USO • NORME D'USO

COUNTRY OF DESTINATION	APPLIANCE CATEGORY	GAS AND SUPPLY PRESSURE	TOTAL NOMINAL HEAT INPUTS (HS)
CH CZ ES FR GB IE IT PT SI	I 3+(28-30/37)	Butane (G30) 28-30 mbar Propane (G31) 37 mbar	19.3 kW 1403g/h 19.3 kW 1379g/h
CZ DE DK FI GB IT NL NO RO SE SI	I 3B/P(30)	Butane/Propane 30 mbar	19.3 kW 1403/h
AT CH DE CZ	I 3B/P(50)	Butane/Propane 50 mbar	18.4 kW 1338g/h
PL	I 3B/P(37)	Butane/Propane 37 mbar	21.6 kW 1571g/h

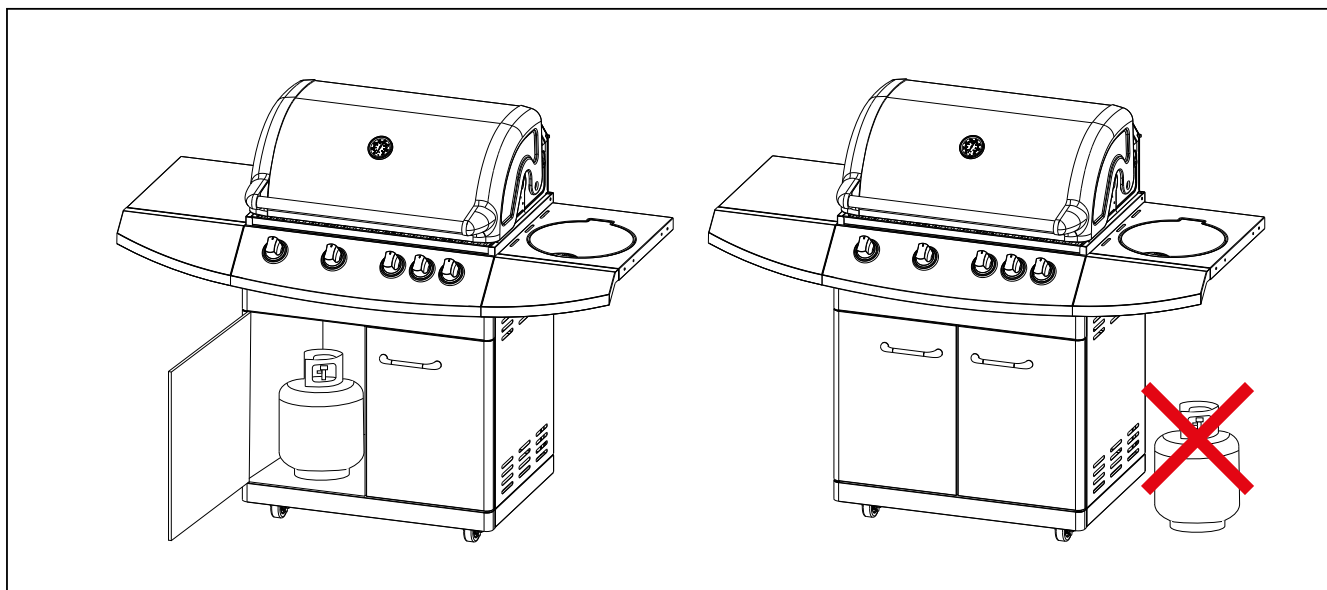

⚠ VORSICHT!

Der Gasgrill ist für den Gebrauch mit einer Gasflasche von 5 kg vorgesehen.
Die Gasflasche darf zum Gebrauch innerhalb des Geräts platziert werden.
Die Gasflasche darf zum Gebrauch nicht unter dem Seitenbrenner platziert werden.
Verwenden Sie nur Gasflaschen, die den nationalen Sicherheitsbestimmungen entsprechen.

⚠ WARNING!

The appliance is designed for use with gas cylinder 5KGS.
The gas cylinder may be placed for use inside the appliance.
The gas cylinder can not be placed under the side burner for using
Only use gas bottles that apply to national regulations!

⚠ ATTENTION!

Le gril à gaz est prévu pour une utilisation avec une bouteille à gaz de 5 kg.
La bouteille de gaz peut être placée à l'intérieur du dispositif pour une utilisation.
La bouteille de gaz ne doit pas être placée sous le brûleur latéral.
Utilisez uniquement les bouteilles de gaz qui respectent les normes de sécurité nationales

⚠ ADVERTENCIA!

La barbacoa a gas está prevista para el uso con una bombona de gas de 5 kg.
La bombona de gas puede ser colocada para su uso dentro del dispositivo.
La bombona de gas no debe colocarse para su uso debajo del quemador lateral.
Utilice sólo cilindros de gas que se ajusten a las normativas nacionales de seguridad.

⚠ AVVERTENZA!

Il barbecue a gas è progettato per essere utilizzato con una bombola di gas di 5 kg.
La bombola di gas può essere collocata all'interno del dispositivo per l'utilizzo.
La bombola di gas non deve essere collocata sotto al bruciatore laterale per essere utilizzata.
Utilizzare esclusivamente bombole di gas conformi alle normative di sicurezza nazionali.



www.mayergrill.com

Mayer Barbecue®

© 2016 Designed and engineered by Mayer Barbecue

Mayer Barbecue ist eine eingetragene Marke der Schoenberger Germany Enterprises GmbH & Co. KG Zechstr. 1-7, 82069 Hohenschäftlarn